



## Assembly Guide Prokraft Premium seam ripper Kits

Please read this guide fully before attempting to assemble your seam ripper.

Drill size: 8mm

Blank length: 81mm min

Bushing set: 11mm – Blade end & 10.2mm finial end

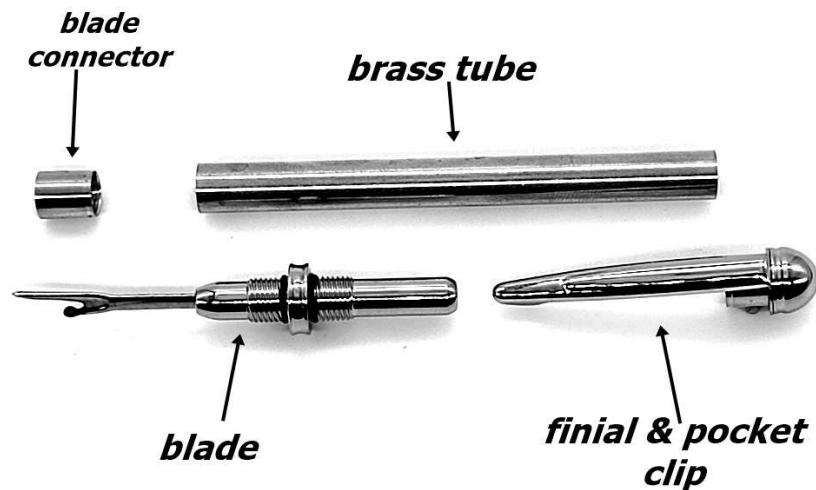

There are 2 parts to assemble in the seam ripper kits, the blade connector and finial/clip.

Once you have glued, turned and finished your blank/tube:

1] press-fit the blade connector – there is a rebate at one end to guide it onto the brass tube. It should be fitted so the connector is fully inside the brass tube and none is left protruding. The connector is made from brass which is a soft metal – it is important that when inserting it is fully level with the tube. Do NOT attempt to insert at an angle.

2] Once the connector is in place push-fit the finial at the opposite end

3] The blade can then be screwed in either direction as required, the rubber rings are provided to reduce the thread coming loose during use.

Your seam ripper is ready for use – please take care with pointed parts to avoid injury

